

F360L-4C-S Side-Emitter Lens for Cree XLamp™ LEDs

- High efficiency
- High-temperature material
- Easy assembly

The F360L-4C-S lens is specifically designed for the Cree XLamp LEDs.

A software-optimized profile provides a 360-degree pattern with high collection efficiency reaching 85% of the total flux emitted from the LED.

The lens flange can be glued to the PCB to provide a secure assembly.

Typical applications are:

360-degree illumination devices, such as:

- Beacons
- Navigation lights
- Warning lights
- Electronic flares

Reflector-based systems requiring excellent light control and/or minimal direct light, such as:

- Streetlights
- Flashlights/torches
- Task lights
- Channel-letter signs
- Spot-lights

This datasheet provides F360L-4C-S lens performance information for the following Cree XLamp LEDs:

- XB-D
- XP-C
- XP-E
- XP-G
- XQ-E

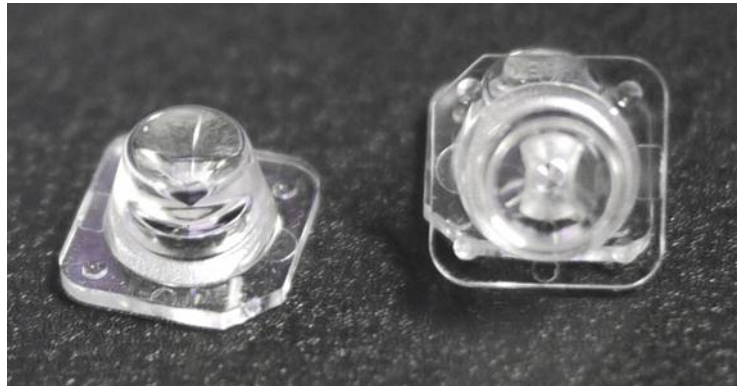

- (1) For technical specification on Cree XLamp LEDs please refer to the product datasheet or visit www.cree.com/led-components-and-modules
- (2) Typical beam divergence may change with LED color temperature and binning.

FRAEN Corporation OMG

80 Newcrossing Road
Reading MA 01867
USA
Phone: +1 781.205.5300
Fax: +1 781.942.2426

FRAEN Corporation Srl

Via delle Querce, 26
27020 Trivolzio (PV)
Italy
Phone: +39 0382 1933.1
Fax: +39 0382 1933.239

Inquiries: optics@fraen.com
Website: FraenOMG.com

For ordering or sales information in your region, please contact one of our offices listed above or visit www.FraenOMG.com/Contact.



General Characteristics

Lens Material	Polycarbonate, UV Stabilized, UL94 V2 rated
Operating Temperature range	-40°C / + 128°C
Storage Temperature range	-40°C / + 128° C

Average transmittance in visible spectrum (400 – 700nm) >85%.

Please note that flow lines and weld lines on the external surfaces of the lenses are acceptable if the optical performance of the lens is within the specification described in the section "OPTICAL CHARACTERISTICS"

IMPORTANT NOTE – Lenses handling and cleaning:

- *Handling: Always use gloves to handle lenses and/or handle the lenses only by the flange. Never touch the outside surfaces of the lenses with fingers; finger oils and contamination will absorb or refract light.*
- *Cleaning: Clean lenses only if necessary. Use only soap and water to clean the surfaces and lenses. Never expose the lenses to alcohol, as it will damage the plastic.*

Scope

This datasheet provides information about the F360L-4C-S lens for Cree XLamp LEDs.

Optical Characteristics

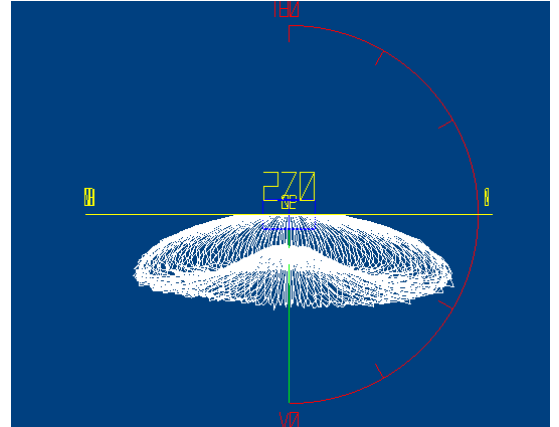
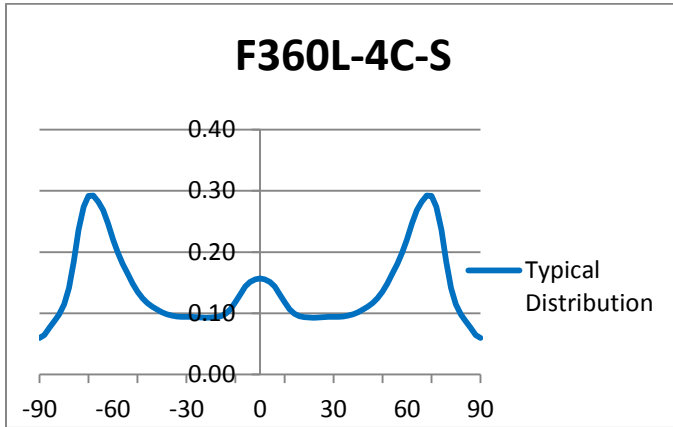

Figure 1: Typical F360L Light Distribution

LED	Peak Intensity		Half Peak Intensity	
	Candela / Lumen	Angle (degrees)	Candela / Lumen	Angle (degrees)
XB-D Cool White	0.24	±69°	0.12	±53° and ±84°
XP-C White	0.33	±71°	0.12	±57° and ±79°
XP-E Cool White	0.27	±69°	0.11	±52° and ±81°
XP-G Cool White	0.23	±69°	0.12	±50° and ±83°
XQ-E White	0.29	±67°	0.15	±54° and ±80°

Table 1: Performance Data

Illumination Calculations

To calculate the intensity (candela) at a specific angle, read the candela/lumen value from the graph in Figure 1, and multiply this value by the total flux of the LED used. Refer to the LED datasheet for nominal lumens values. For a more accurate calculation, refer to the intensity “ranking” (binning) tables on the datasheet for the specific LED.

Example calculations:

If the Fraen F360L-4C-S is used on a cool neutral white LED at 350 mA, a typical luminous flux of the LED might be 80 lumens.

The calculation is: $(0.22 \text{ candela/lumen}) \times (80 \text{ lumens}) = 17.6 \text{ candela}$, at $\pm 69^\circ$ off-axis.

At $\pm 45^\circ$ and $\pm 85^\circ$ off-axis, the intensity is $\frac{1}{2}$ of the peak. This means at $\pm 45^\circ$ and $\pm 85^\circ$ off-axis, the intensity should be $\frac{1}{2}$ of 17.6 candela, or 8.8 candela.

One candela at 1-meter distance produces 1 Lux. The peak intensity at 1 meter will be 17.6 lux. The intensity decreases as a function of the distance squared. At 2 meters the peak intensity will be $17.6 / (2^2) = 4.4 \text{ lux}$. At 3 meters distance, the peak intensity will be $17.6 / (3^2) = 2.0 \text{ lux}$.

Mechanical Characteristics

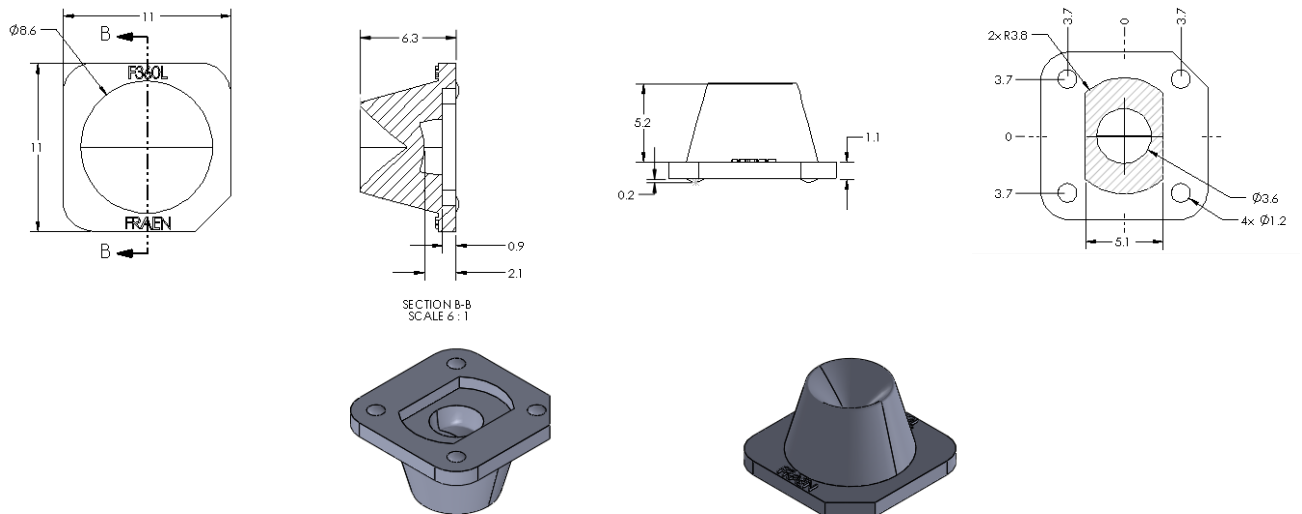

All dimensions in millimeters. Tolerances: +/-0.1 mm

Figure 2: Dimensions of the F360L-4C-S lens

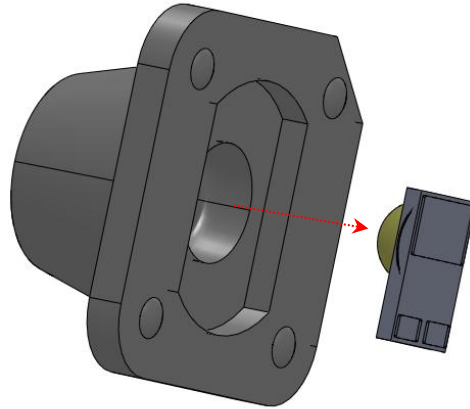

Figure 3: The center of the F360L-4C-SS lens should be aligned with the center of the LED dome lens. There is sufficient clearance in the bottom of the F360L-4C-S lens to accept the rectangular LED package.

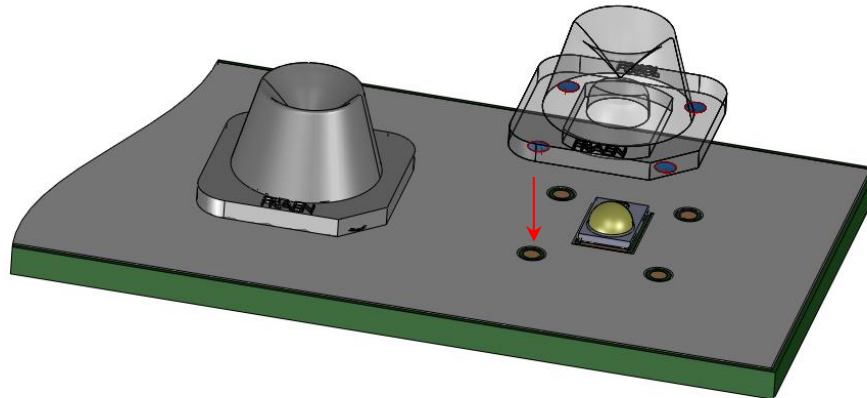

Figure 4: The square flange of the F360L-4C-S lens has 4 bumps, which are intended to fit four corresponding recesses in the PCB solder-mask.

See *Figures 2 and 7* for locating pin layout and dimensions.

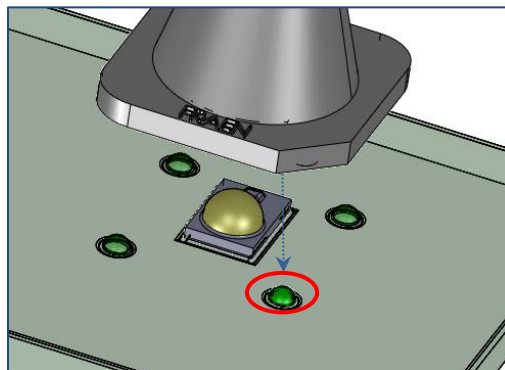

Figure 5: A small droplet of glue is placed at each of the 4 solder-mask recess locations, to bond the 4 lens “bumps” to the PCB. A fixture or automated placement machine will be required to assure proper lens location (to center the lens to the LED die).

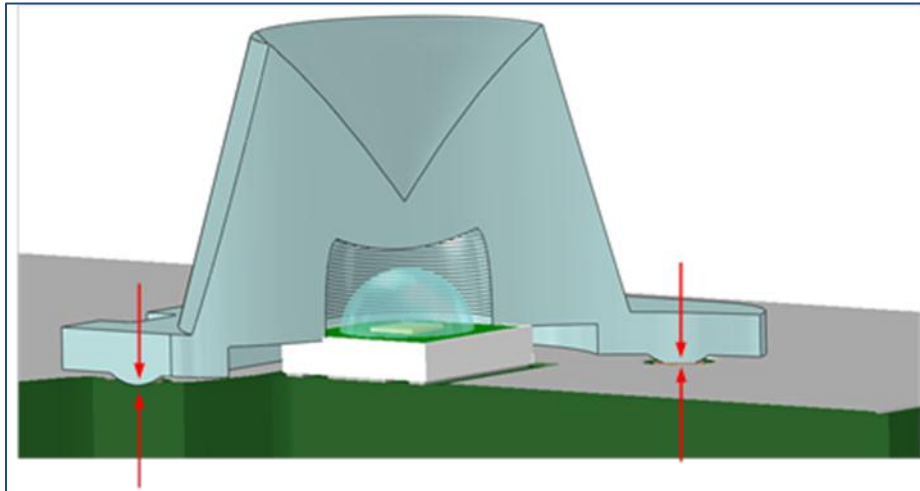

Figure 6: The correct height is achieved when the lens bumps touch the PCB copper (same plane as LED solder).

DESIGN NOTE: Proper lens to LED alignment requires that the PCB have recesses to accommodate the locating pins on the lens

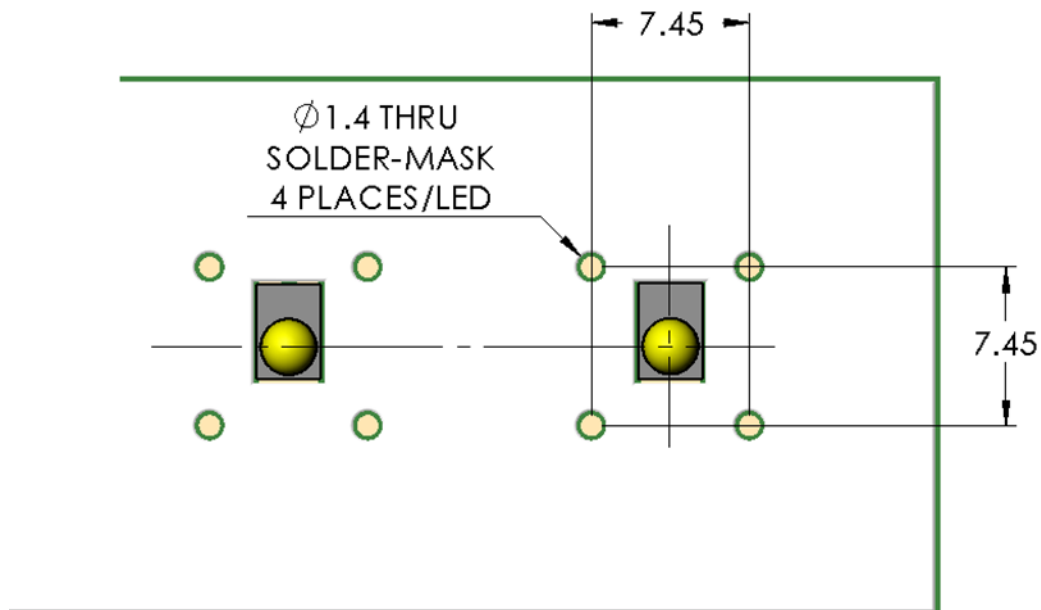

Figure 7: Dimensions and layout of the PCB location recesses used to align the lens to the LED. (All dimensions in millimeters)

Packaging Information – Tape & Reel

The F360L-4C-S lens is available only in Tape & Reel packaging. Reel capacity: 500 lenses in pockets with a ten pocket (empty) leader and a five-pocket trailer.

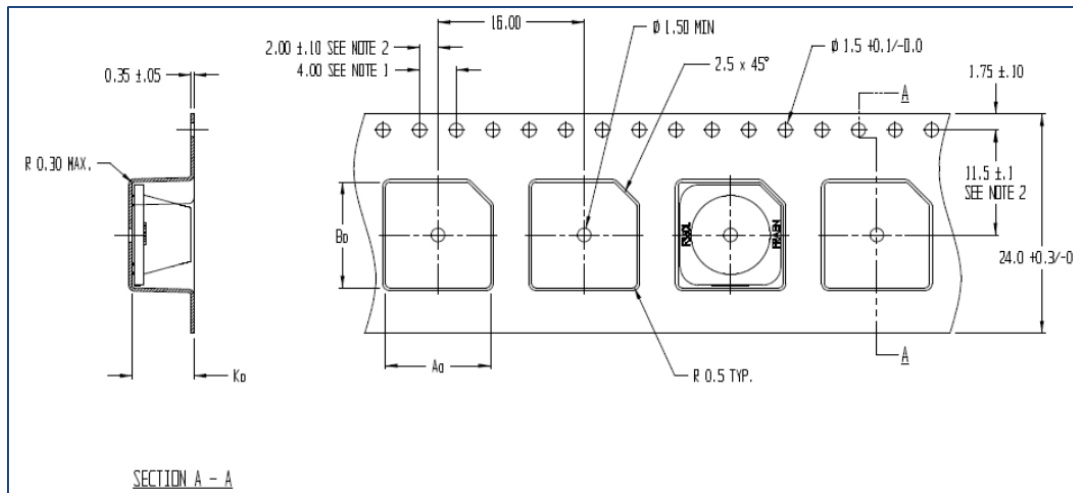

Figure 8: Tape dimensions and layout
(All dimensions in millimeters)

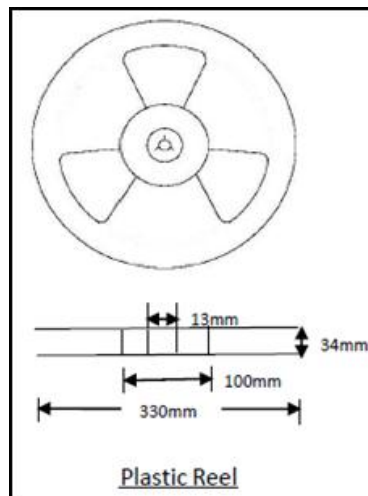

Figure 9: Reel dimensions

Ordering part number

F360L-4C-S